

MYTECH®

SHOU ZUAN
Precision Machinery Co., Ltd.

No.46 Gen-Chen Rd., Shen Kung Dist.,
Taichung City 42952, Taiwan.

Tel.+886-4-2563 3015 · +886-4-2515 0719
Fax.+886-4-2563 2838 · +886-4-2515 7380
E-mail. sales@mytech-cnc.com

www.mytech-cnc.com

We reserve the right to modify design without prior notice.

精
準
工
具
磨
削
機

● ● ● ● ● Cathay Design 886-4-2563265 2017.04



MYTECH®

ELEGANCE IN TECHNOLOGY



PCD & PCBN Tool Grinding Machin





MT-188

Application Materials

- MT-188 is easy to operate, it can manufacture and regrind insert tools very economically.
- Not only grinding cutting tools which is made of PCD/PCBN, but also tungsten carbide and HSS tools.
- The MT-188 PCD & PCBN Tool Grinding Machine, is a versatile machine, perfectly suited for manufacture and sharpen high-quality tools.

PCD/PCBN
Tungsten carbide
HSS.



MT-198

Application Materials

- MT-198 spindle can be raised and lowered, B axis braking system and MPG handwheel provides added convenience in machine running test when production of special tools.
- MT-198 PCD & PCBN Tool Grinding Machine, is a versatile machine, perfectly suited for manufacture and sharpen high-quality tools.
- The high-end machine, MT-198 has creative technologies to make it convenience to machine a wide range of special tools such as, spindle can be vertical movement, B axis braking system and MPG handwheel for easy setting and running test.

PCD/PCBN
Tungsten carbide
HSS.

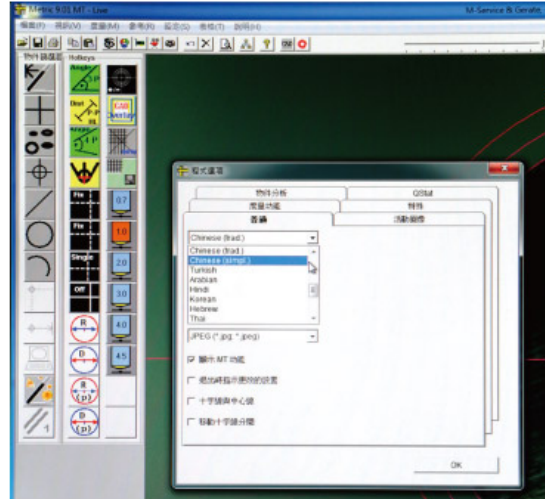

Germany Brand CCD System

The grinding machine equipped with German high-precision camera system and measurement software. The major performance features include: multiple language is available and CAD graphics and geometry in process measurement. Precision and productivity has been greatly improved.

High Quality Casting Of Column and Base

The major machine elements, such as base, table and wheelhead are all analyzed by Computational Fluid Dynamics (CFD) to optimize the machine construction. This design performs the best structural dynamics with minimum deformation.

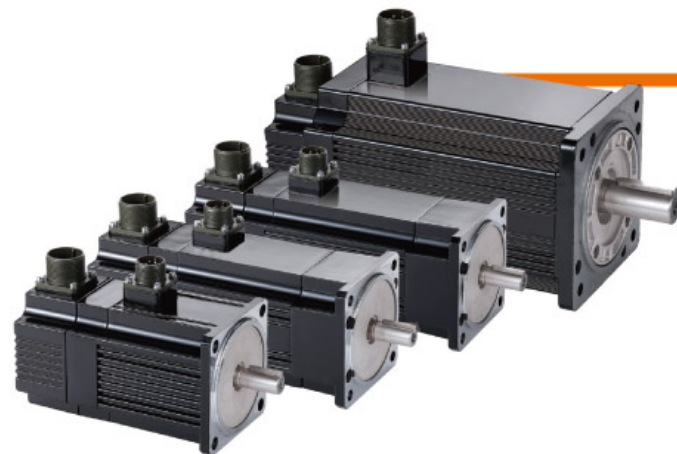

Servo Motor

The brushless servo spindle motor is much better than tradition motors that has the features of smaller, lighter, higher-torque, high-efficiency (2.2KW) and Max. speed 6000 rpm/min.

Roller Type Linear Guideway

To maximize stability and load capacity, the swing axis and position the axis are equipped with SCHNEEBERGER wide span and precision linear ways. No matter heavy duty or fine grinding, can to meet various machining requirements.



MPG (MT-198 Standard)

The MPG handwheel provides added convenience in machine running test.

Automatic Lubricator

The automatic lubricator supplies lubrication to precision linear ways and roller ensuring high damping performance, long-term smooth feed and precise grinding.





Coolant System (Option)

Large capacity 100-liter tank with the bag filters keep coolant clean for a long time to assure highest quality possible.

Universal work table (Option)

The single axis can rotate work table and dual axes can tilt work table for tool's back angle grinding.



Wheel dresser (Option)

The workbench type wheel dresser is equipped with power motor for dressing diamond grinding wheels. The accessory now has the features of compact design, quick setups and reduction of non-cutting idle time.

High precision dividing head (Option)

For clamp round tools, the precision ground indexing plate has 24 indexing locations in 15° increments also can fine adjustment the tune the angle. They're commonly used with NANN precision collet and flange to achieve optimal performance increase.

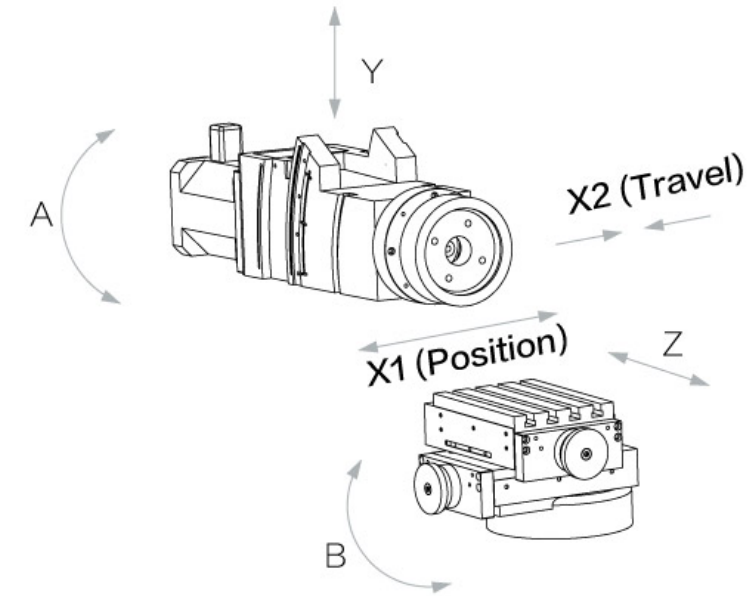
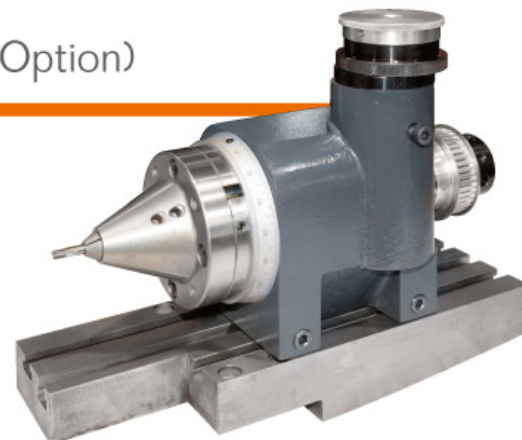

V Standard O Option X Not

SPEC.	MT-188	MT-198
Spindle speed	0 ~ 6000 rpm/min (50Hz)	0 ~ 6000 rpm/min (50Hz)
Wheel size	150 D x 40 H x 40 T	150 D x 40 H x 40 T
Grinding pressue	0 ~ 0.4 MPa	0 ~ 0.4 MPa
Grinding wheel oscillation distance	0 ~ 40 mm	0 ~ 40 mm
Grinding wheel oscillation stroke	40 次/min	40 次/min
Grinding wheel oscillation position	0 ~ 188 mm	0 ~ 198 mm
Grinding wheel inclindtion	-2° ~ 24°	-2° ~ 24°
Swivel table swiveling angle	270°	270°
Table size	210 x 160 x 4 slot	210 x 160 x 4 slot
External dimoensions	1396 x 1601 x 1582 mm	1495 x 1580 x 1710 mm
Y axis mpg	X	O
X1 axis mpg	X	V
X2 axis mpg	X	V
A axis mpg	X	O
Z axis air pressure	V	V
B axis brakes	O	O
Spindle with variable speed	V	V
Grinding wheel spindle with variable speed	V	V
22" lcd monitor	V	V
High resolution camera and measurment system (std. 105x / opt. 210x)	V	V
Tool stand	12, 16, 20, 25, 32	12, 16, 20, 25, 32
Z axis dro	V	V
B axis dro	V	V
X axis dro	O	V
Y axis dro	X	V
A axis dro	X	O
Led work lamp	2 pcs	2 pcs
Grinding wheel	3 pcs	3 pcs
Net weight	1800 KGS	2400 KGS